

+ WP TOT

+ 0.0 WP 1 TOT 0.0

+ 5.3 WP 2 TOT 5.3

+ 3.4 WP 3 TOT 8.7

+ 0.5 WP 4 TOT 9.2

+ 2.7 WP 5 TOT 11.9

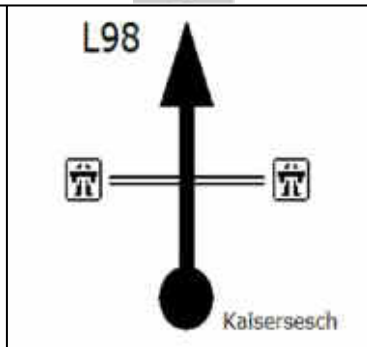
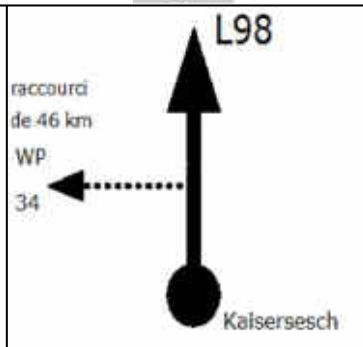
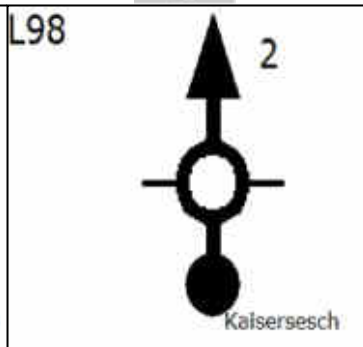
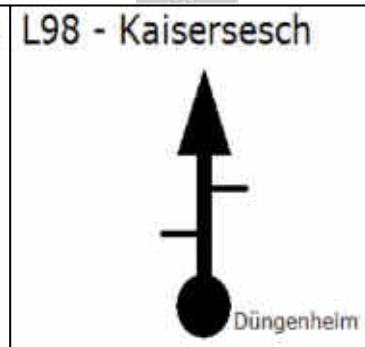
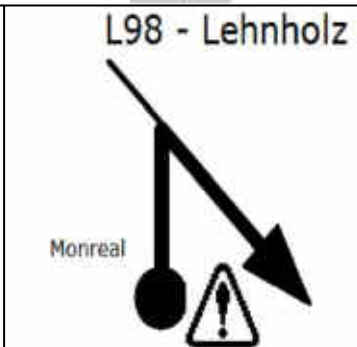
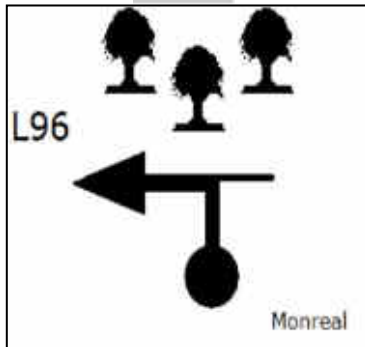

+ 2.7 WP 6 TOT 14.6

+ 1.5 WP 7 TOT 16.1

+ 6.7 WP 8 TOT 22.8

+ 2.3 WP 9 TOT 25.1

+ 0.7 WP 10 TOT 25.8

+ 0.3 WP 11 TOT 26.1

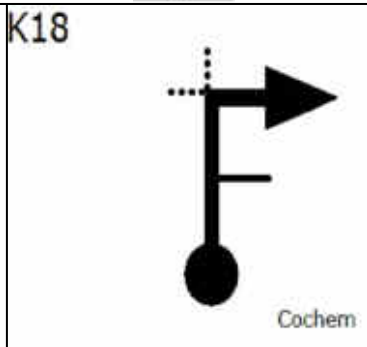
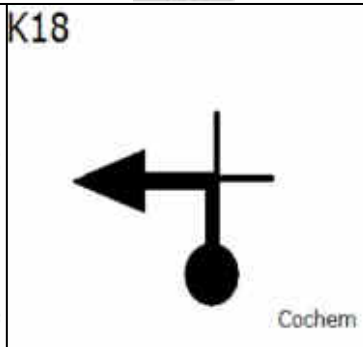
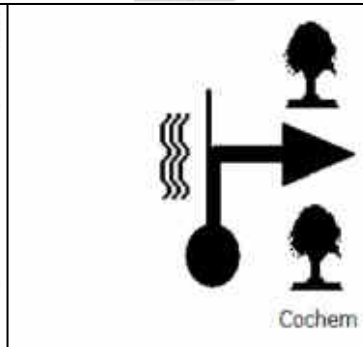
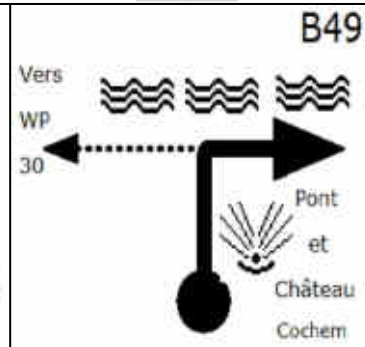
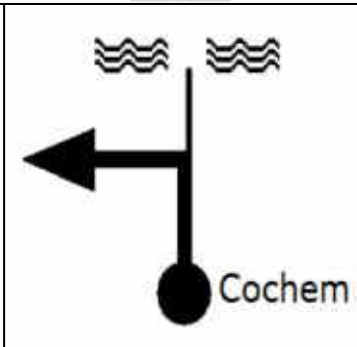
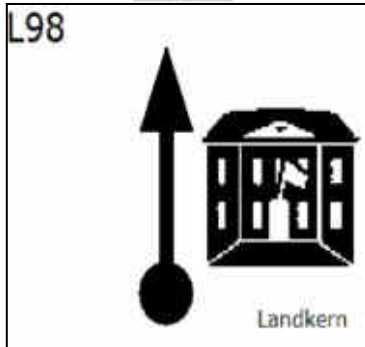

+ 4.3 WP 12 TOT 30.4

+ 7.2 WP 13 TOT 37.6

+ 0.3 WP 14 TOT 37.9

+ 0.3 WP 15 TOT 38.2

+ 0.1 WP 16 TOT 38.3

+ 0.0 WP 17 TOT 38.3

|   |                                  |                                  |  |  |                                |
|---|----------------------------------|----------------------------------|--|--|--------------------------------|
| <p>K18 - Dohr - Faid</p>                | <p>K18</p> <p>Dohr</p>           | <p>K22</p> <p>Cochern</p>        | <p>B259 - Shel</p> <p>Cochern</p>            | <p>B49 - Ebernach</p> <p>Sehl</p>              |                                |
| <p>+ 4.0 WP 18 TOT 42.3</p>             | <p>+ 0.1 WP 19 TOT 42.4</p>      | <p>+ 0.3 WP 20 TOT 42.7</p>      | <p>+ 0.2 WP 21 TOT 42.9</p>                  | <p>+ 5.9 WP 22 TOT 48.8</p>                    | <p>+ 4.4 WP 23 TOT 53.2</p>    |
| <p>Bruttig - Fankel</p>                 | <p>L98</p> <p>Bruttig-Fankel</p> | <p>K36</p> <p>Bruttig-Fankel</p> | <p>Maria Engelport</p> <p>Bruttig-Fankel</p> | <p>L202 - Treis-Karden</p> <p>Treis-Karden</p> | <p>B49</p> <p>Treis-Karden</p> |
| <p>+ 0.5 WP 24 TOT 53.7</p>             | <p>+ 0.2 WP 25 TOT 53.9</p>      | <p>+ 1.0 WP 26 TOT 54.9</p>      | <p>+ 7.9 WP 27 TOT 62.8</p>                  | <p>+ 8.6 WP 28 TOT 71.4</p>                    | <p>+ 0.9 WP 29 TOT 72.3</p>    |
| <p>K37 - Karden</p> <p>Treis-Karden</p> | <p>L108</p> <p>Treis-Karden</p>  | <p>L110 - Brohl</p> <p>Brohl</p> | <p>L110</p> <p>Brohl</p>                     | <p>K27 - Pyrmont ...</p> <p>Roes</p>           | <p>Roes</p>                    |
| <p>+ 0.3 WP 30 TOT 72.6</p>             | <p>+ 0.7 WP 31 TOT 73.3</p>      | <p>+ 3.7 WP 32 TOT 77.0</p>      | <p>+ 1.4 WP 33 TOT 78.4</p>                  | <p>+ 2.7 WP 34 TOT 81.1</p>                    | <p>+ 1.1 WP 35 TOT 82.2</p>    |

|                                 |   |                          |   |  |                                     |
|---------------------------------|---|--------------------------|---|--|-------------------------------------|
| <p>Pillig</p>                   | <p>L110 - Naunheim</p> <p>Pillig</p>    | <p>L82 - Naunheim</p>    | <p>L82 - Kollig</p> <p>Mertloch</p>                 | <p>K28 - Kehrig</p> <p>Gering</p>        | <p>K25 - Mayen</p>                  |
| + 3.1 WP 36 TOT 85.3            | + 0.5 WP 37 TOT 85.8                    | + 1.3 WP 38 TOT 87.1     | + 2.6 WP 39 TOT 89.7                                | + 3.9 WP 40 TOT 93.6                     | + 6.0 WP 41 TOT 99.6                |
| <p>L82</p> <p>Mayen</p>         | <p>L82 L83</p> <p>Mayen</p>             | <p>L83</p> <p>Mayen</p>  | <p>L83 - Burrenheim</p> <p>Mayen</p>                | <p>L10 Kirckesch</p> <p>Sankt Johann</p> | <p>K11 - Acht</p> <p>Langenfeld</p> |
| + 2.2 WP 42 TOT 101.8           | + 0.4 WP 43 TOT 102.2                   | + 0.4 WP 44 TOT 102.6    | + 0.2 WP 45 TOT 102.8                               | + 4.1 WP 46 TOT 106.9                    | + 9.9 WP 47 TOT 116.8               |
| <p>K11 - Büchel</p> <p>Acht</p> | <p>K11 - Wanderath</p> <p>Virneburg</p> | <p>Hotel</p> <p>Baar</p> | <p>Finish</p> <p>MERCI</p> <p>www.rando-moto.be</p> |  |                                     |
| + 2.2 WP 48 TOT 119.0           | + 3.9 WP 49 TOT 122.9                   | + 2.5 WP 50 TOT 125.4    | + 0.3 WP 51 TOT 125.7                               | + WP TOT                                 | + WP TOT                            |